

Pressure reducing valve in straightway form
NPS 1" - 6"

ARI-PREDU® - ANSI
Pressure regulating valve, straight
through with diaphragm actuator DMA

- Actuator with rolling diaphragm

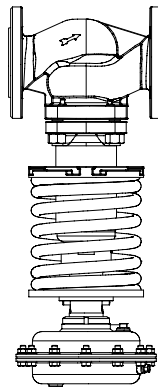

Cast steel
Fig. 701

Page 2

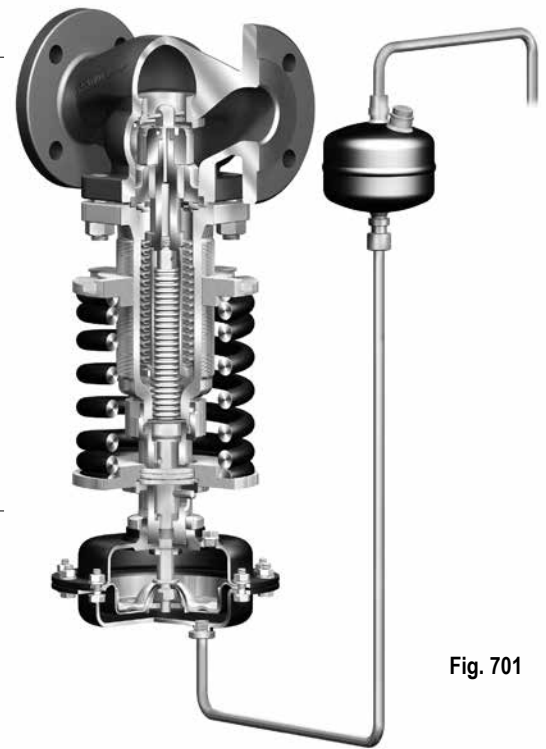

Fig. 701

Features:

- Compact design
- Construction without pillars
- Exact and easy adjustment
- Diameter independent ranges
- Simple change of spring and actuator
- 5 exchangeable actuator sizes
- 3 exchangeable spring sizes
- Pressure balanced by stainless steel bellow
- Spindle sealing via stainless steel bellow
- Secondary stem sealing (optional)
- Tapered seat ring
- Screwed seat ring
- Kvs-value reduceable
- Flow divider for noise reduction (optional)
- Plug with PTFE soft sealing (optional)

Pressure regulating valve, straight through with diaphragm actuator DMA

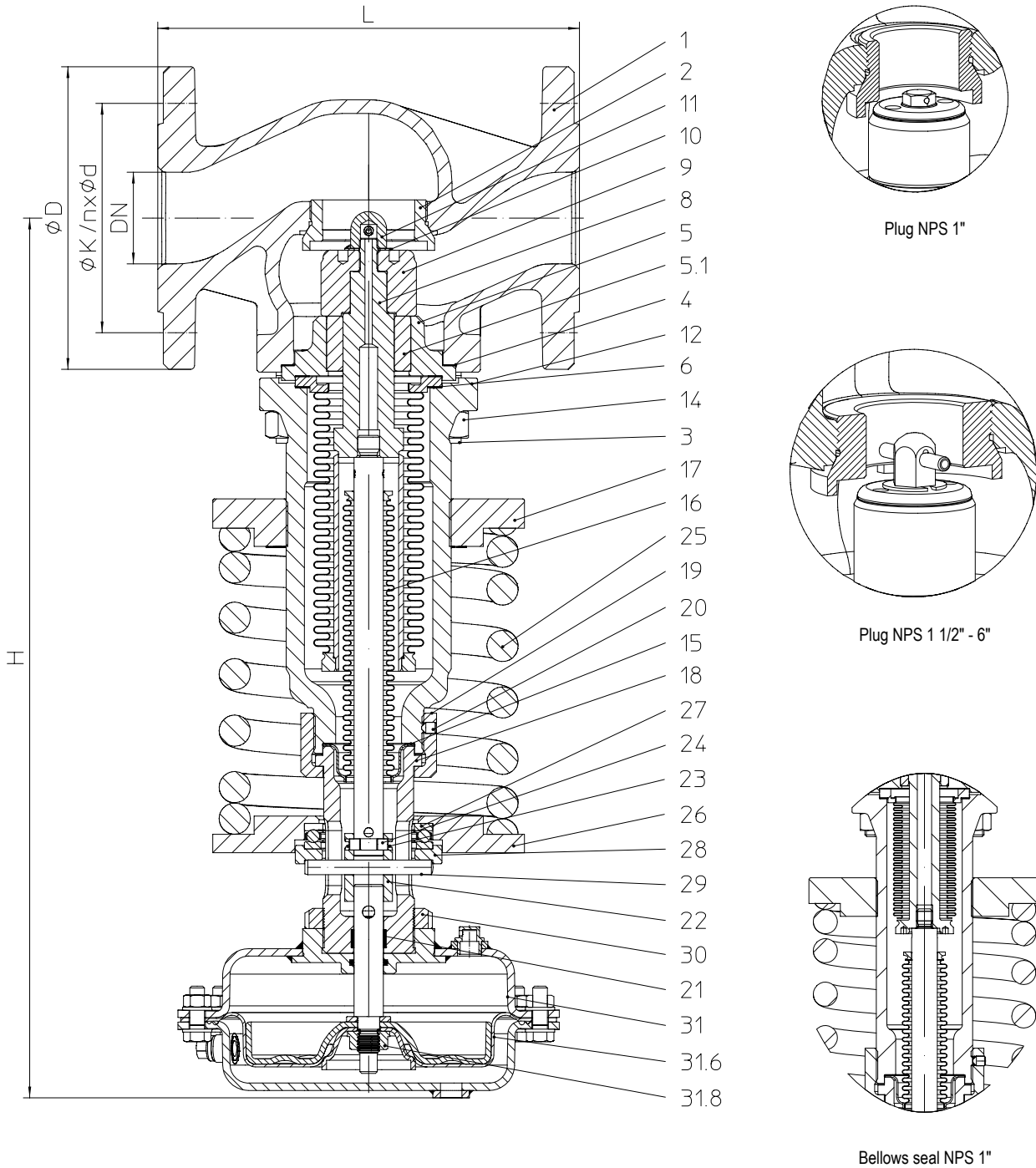

Figure	Nominal pressure	Material	Nominal diameter	Downstream-pressure ranges	Actuator
32.701....90	ANSI150	SA216WCB	NPS 1" - 6"	0,2 - 16 barg	DMA 400
35.701....90	ANSI300	SA216WCB	NPS 1" - 6"		D-MA 250
					DMA 160
					DMA 80
					DMA 40
Technical data for the actuator refer to page 6.					

NPS		1"	1 1/2"	2"	3"	4"	6"	
Kvs-value								
Kvs-value	standard	(m ³ /h)	8	20	32	80	125	280
	reduced	(m ³ /h)	0,1 / 0,4 / 1 / 2,5 / 4 / 6,3	--	--	--	--	--
Seat-ø		(mm)	25	40	50	80	100	150
Travel		(mm)	6	8	10	13	16	22
Max. differential pressure drop		(bar)	25	25	25	20	20	16
Shut off class	Leakage class I acc. to ANSI / FCI 70-2 (≤ 0,05% from Kvs-value)							

Face-to-face dimension Form RF acc. to ANSI / ISA - S75.03-1992			(Face-to-face dimension Form RTJ on request.)					
L	ANSI150	(mm)	184	222	254	298	352	451
	ANSI300	(mm)	197	235	267	317	368	473

Flanges acc. to ANSI B16.5								
ØD	ANSI150	(mm)	108	127	153	191	229	279
	ANSI300	(mm)	124	155	165	210	254	318
ØK	ANSI150	(mm)	79	98	121	152	191	241
	ANSI300	(mm)	89	114	127	168	200	270
n x Ød	ANSI150	(mm)	4 x 16	4 x 16	4 x 19	4 x 19	8 x 19	8 x 22
	ANSI300	(mm)	4 x 19	4 x 22	8 x 19	8 x 22	8 x 22	12 x 22

Dimensions								
H	DMA 400	(mm)	500	540	540	585	610	690
	DMA 250	(mm)	460	500	500	545	585	650
	DMA 160	(mm)	440	480	480	530	550	630
	DMA 80	(mm)	440	480	480	530	550	630
	DMA 40	(mm)	440	480	480	530	550	630

Weights								
32.701....90 / 35.701....90	with DMA 400	(kg)	28	35	41	70	85	158
	with DMA 250	(kg)	23	30	36	65	83	156
	with DMA 160	(kg)	21	28	34	63	81	154
	with DMA 80	(kg)	20	27	33	62	80	153
	with DMA 40	(kg)	19	26	32	61	79	152

Downstream-pressure ranges							
	(barg)	0,2 - 0,6	0,5 - 1,2	0,8 - 2,5	2 - 5	4,5 - 10	8 - 16
Pneumatic Actuator DMA	(cm ²)	DMA 400	DMA 250	DMA 160	DMA 80	DMA 40	
Pneumatic Actuator PN-max.	(barg)	1,6	2,5	6	10	20	
Spring end-No.		04	04	07	07	07	10

NPS	1"	1 1/2"	2"	3"	4"	6"
-----	----	--------	----	----	----	----

Proportional ranges (Combination: actuator with valve in ± bar)									
Pneumatic Actuator (cm ²)	DMA 400	Downstream pressure range (barg)	0,2 - 0,6	0,05	0,05	0,06	0,08	0,08	0,15
	DMA 250		0,5 - 1,2	0,06	0,09	0,09	0,15	0,10	0,23
	DMA 160		0,8 - 2,5	0,15	0,20	0,25	0,30	0,35	0,50
	DMA 80		2,0 - 5,0	0,40	0,35	0,40	0,50	0,60	0,90
	DMA 40		4,5 - 10,0	0,60	0,70	0,75	0,85	0,90	1,35
	DMA 40		8,0 - 16,0	1,00	1,10	1,25	1,50	1,75	2,00

Pressure reducing valves are proportional regulators with permanent control deviation depending from the construction.
 The actual control deviation depends on the valve load.

(Kv-value / Kvs-value-max) x Proportional range = Actual control deviation
 The values shown are preliminary values and may vary by the real plant

Pressure-temperature-ratings Intermediate values for max. permissible operational pressures can be determined by linear interpolation of the given temperature / pressure chart.

acc. to ANSI B16.5				-29°C to 38°C	93°C	149°C	204°C	260°C	315°C	343°C
32.701....90	SA216WCB	ANSI150	(bar)	19,6	17,9	15,8	13,8	11,7	9,6	8,6
35.701....90	SA216WCB	ANSI300	(bar)	51,1	46,6	45,2	43,8	41,4	39,3	37,9

Application

The pressure regulating valve is a direct acting proportional regulator, self operated; which regulates a high inlet pressure to a smaller downstream pressure. The downstream pressure is regulated, this means the valve closes when the downstream pressure rises.

Operating fields are to regulate fluids of the group II acc. to Pressure Equipment Directive 2014/68/EU, e.g. steam, neutral gases, vapours and liquids. With steam and liquids, having temperatures higher than the allowable working temperatures a water seal pot must be installed in the control line (to protect actuator diaphragm) (refer to page 6).

Installation in the control line can be seen in the system drawing:

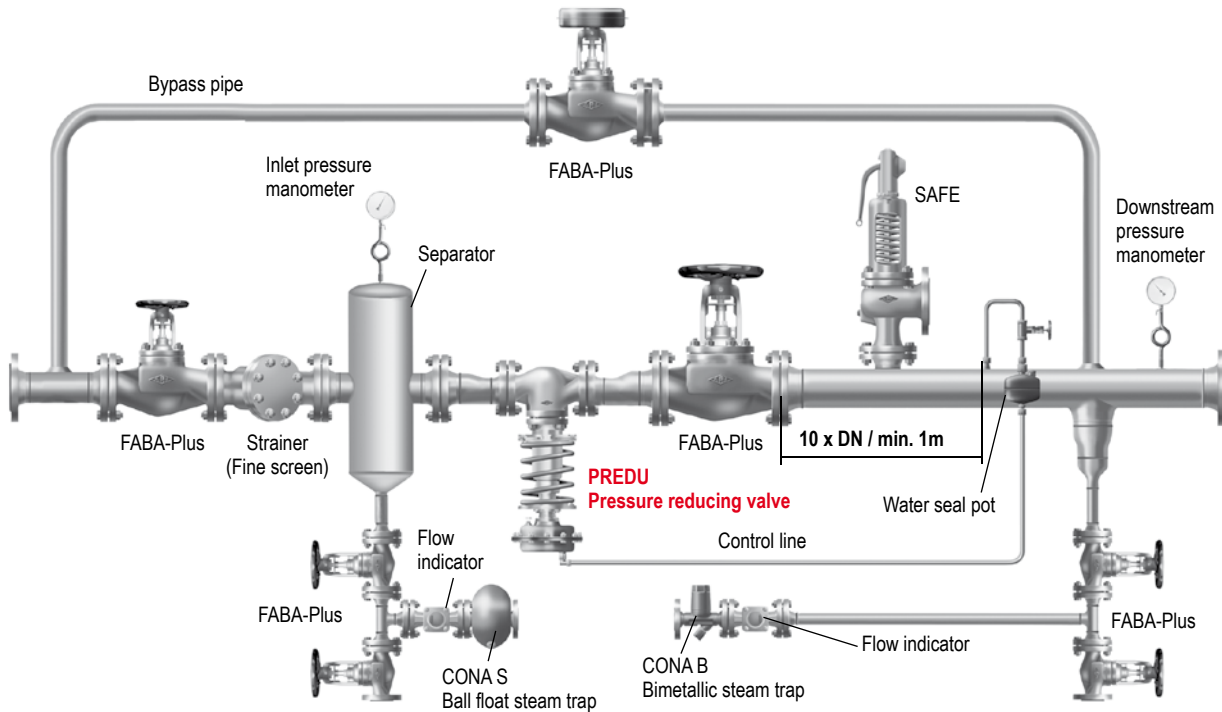

Sizing

For the calculation you have the program myValve (Program part „Pressure reducing valves“). After giving in the process data, the Fig.-No. and size is recommended out of the integrated data bank. The diameter of the piping in front and behind of the pressure regulating valve can also be calculated with the max. allowable flow velocities with myValve.

The necessary downstream pressure gives the needed pressure range. Because the regulation tolerance at the end of the range is smaller, the smaller range must be used, in case of a range overlapping. For example: Downstream pressure 2,4 bar(g), choose actuator range 0,8 - 2,5 bar(g), although 2-5 bar(g) could be used.

The safety valve used to secure the downstream pressure must have an adequate distance between set pressure and downstream pressure. The max. possible capacity of the pressure reducing valve is used to select the safety valve at it's set pressure. The max. possible capacity has to be calculated with p_1 (= max. possible inlet pressure), p_2 (= set pressure of the safety valve) and the Kvs-value of the pressure reducing valve with myValve. With this found capacity you can, with myValve (Program part: Safety valves), select the safety valve, and with the pressure reducing valves and other valves, administer them under a project.

Important: If not secured that the bypass valve has a larger capacity than the pressure reducing valve, or that it can be open parallel, then the extra capacity must be considered for the safety valve sizing.

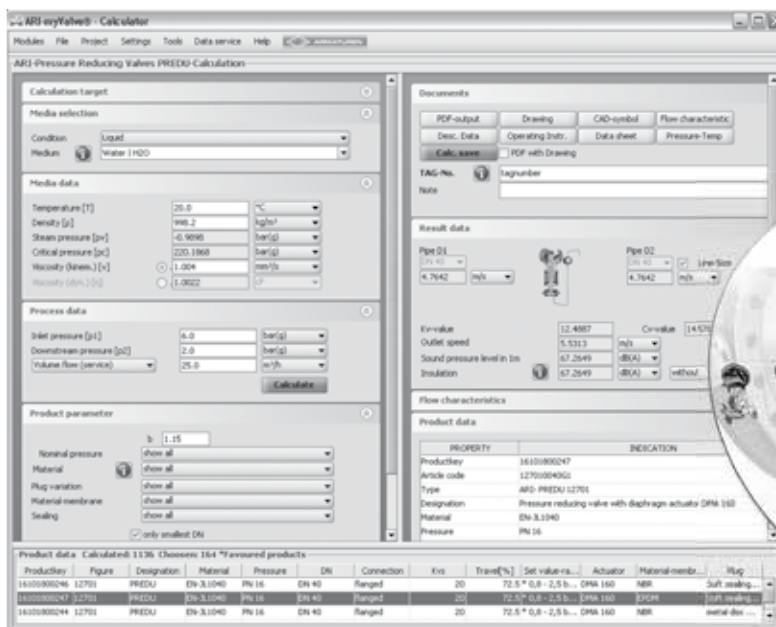

Parts			
Pos.	Ers.	Description	Fig. 32.701 Fig. 35.701
1		Body	SA216WCB
2	x	Screwed seat ring	AISI 420
3		Stud	SA193-B7-A2B
4	x	Gasket	Pure graphite (CrNi laminated with graphite)
5		Bush housing	SA395
5.1		Guide bush	AISI 420
6	x	Gasket	Pure graphite (CrNi laminated with graphite)
8	x	Balanced-bellow-unit	SA182F316Ti / SA240Gr.304 / AISI 420
9	x	Plug unit	AISI 420 (hardened)
10		Washer	A2
11		Hexagon screw	< NPS 1 1/2": A4-70
11		Head	≥ NPS 1 1/2": SA182F316Ti / AISI 420
12		Bonnet Fig. 700 closed	SA395
14		Hexagon nut	SA194-2H-A2B
15	x	Gasket	Pure graphite (CrNi laminated with graphite)
16	x	Sealing-bellow-unit	SA182F316Ti / SA240Gr.304 / AISI 420
17		Adjusting plate	SA395
18		Head	SA395
19		Screw joint	AISI 1213
20		Thread pin	45H - A2B
21		Guide bush	PTFE-25%C
22		Guide coupling	AISI420
23		Cylindrical balls	AISI 52100
24		Securing wire	AISI 301
25	x	Spring	AISI 6150
26		Spring plate	AISI 1015
27		Axial bearing	AISI 52100
28		Pressure plate	AISI 1213
29		Parallel pin	Steel
30		Slotted nut	5.8 - A2B
31	x	Pneumatic Actuator DMA	
31.6	x	Rolling diaphragm	NBR / EPDM
31.8	x	Collar nut with sealing ring	Steel
		L Spare parts	

Information / restriction of technical rules need to be observed!

Operating and installation instructions can be downloaded at www.ari-armaturen.com.

The engineer, designing a system or a plant, is responsible for the selection of the correct valve.

Resistance and fitness must be verified (contact manufacturer for information, refer to Product overview and Resistance list).

Diaphragm actuator DMA 40 - DMA 400

- Rolling diaphragm
- Connection through a central thread
- Spindle connection with a fast coupling
- Delivered with a flow restrictor and 90°-elbow

Material (Diaphragm):

EPDM -40°C to +130°C

NBR -40°C to +100°C

Selection of possible applications:

- Neutral gases, Vapours and liquids
(only fluids of group II acc. to Pressure Equipment Directive 2014/68/EU)

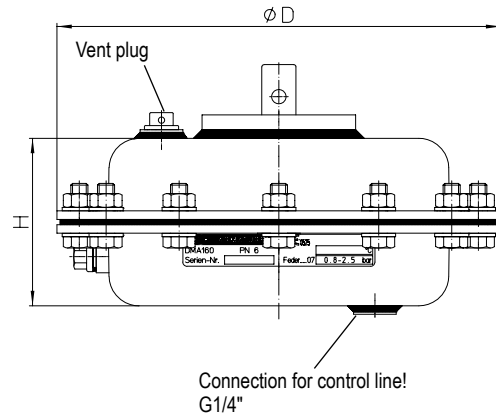

Pneumatic Actuator		DMA 400	DMA 250	DMA 160	DMA 80	DMA 40
ØD	(mm)	300	250	210	170	140
H	(mm)	135	90	80	75	75
Weight	(kg)	13,4	8,1	5,1	3,7	2,9

Water seal pot

(for media temperatures higher than the allowed diaphragm temperature)

- Delivered with a funnel

Selection of possible applications:

- Steam
- Hot water
- Neutral liquids

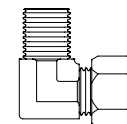
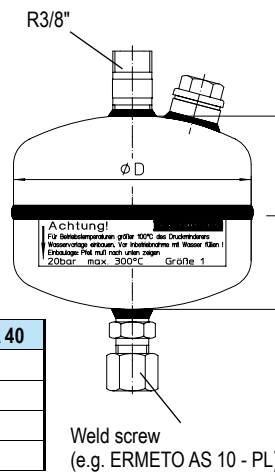

90°-elbow R1/4"
(e.g. ERMETO WE10-LLR)



Flow restrictor
G1/4" / G1/4"

Pneumatic Actuator		DMA 400	DMA 250	DMA 160	DMA 80	DMA 40
Size		2			1	
ØD	(mm)	140			102	
L	(mm)	110			83	
V	(dm ³)	1,2			0,6	



Flow divider for noise reduction



Plug with PTFE soft sealing
(max. 200°C, only for standard Kvs-values)

Please indicate when ordering:

- Figure-No.
- Nominal diameter
- Nominal pressure
- Body material
- Plug version
- Kvs-value
- Pressure range
- Actuator
- Special design / accessories

Example:

Figure 35.701, NPS 2", Nominal pressure ANSI300 / PN40, Body material SA216 WCB, metal seat, Kvs 125, 0,8 - 2,5 bar, ARI-DMA 160 with NBR-Membrane, Water seal pot size 1.



Technology for the Future.
GERMAN QUALITY VALVES

ARI-Armaturen Albert Richter GmbH & Co. KG, D-33750 Schloß Holte-Stukenbrock,
Tel. +49 52 07 / 994-0, Telefax +49 52 07 / 994-158 or 159 Internet: <http://www.ari-armaturen.com> E-mail: info.vertrieb@ari-armaturen.com